



SOP Number	WBEA SOP-ANA-003 NO2
Implementation Date	February 19, 2013
Last Update Date	February 19, 2013
Revision	1.00

WBEA – Standard Operating Procedure

SOP Title	Procedures for operating continuous Nitrogen Oxides (NO_x/NO/NO₂) analyzers
SOP Number	WBEA SOP-ANA-003 NO2
Author	Kelly Baragar
Implementation date	February 19, 2013

Revision History

Revision #	Date	Description	Author



	Page 2 of 10	SOP Number	WBEA SOP-ANA-003 NO2
		Implementation Date	February 19, 2013
		Last Update Date	February 19, 2013
		Revision	1.00

Table of Contents

Introduction and Background	3
Principle of the Method	3
Measurement Range and Sensitivity	5
Equipment and Apparatus	5
Interferences.....	5
Precision and Accuracy	6
Site Requirements.....	6
Installation Requirements.....	6
Operating Parameters and Instrument Configuration.....	7
Daily Requirements.....	7
Analyzer Test Parameters	8
Inlet Filter Change.....	8
Analyzer Maintenance	8
Annual Tasks	8
Semi Annual Tasks.....	8
Multipoint Calibration.....	9
Analyzer Audit.....	9
Calibration Requirement.....	9
Data Collection and Management	10
Reference Documents.....	10

	Page 3 of 10	SOP Number	WBEA SOP-ANA-003 NO2
		Implementation Date	February 19, 2013
		Last Update Date	February 19, 2013
		Revision	1.00

Introduction and Background

This document is intended to be used as a reference for use in the calibration, maintenance and operation of continuous analysis of Oxides of Nitrogen, including Nitrogen Dioxide and Nitric Oxide in ambient air. The proper utilization of this procedure in conjunction with the operators manual will conform to the current Alberta Air Monitoring Directive (AMD) and enable Nitrogen Dioxide data to be included in provincial and national air quality data bases.

Principle of the Method

Oxides of Nitrogen analyzers are based on the principle that nitric oxide (NO) and ozone (O₃) react to produce a characteristic luminescence with intensity linearly proportional to the NO concentration. Infrared light emission results when electronically excited NO₂ molecules decay to lower energy states. Specifically;



The analyzer has two active channels or modes, the NO mode and the NO_x mode. Using the signal data from these two active modes, the NO signal is subtracted from the NO_x signal to give the NO₂ signal. This is accomplished considering the following. Nitrogen dioxide (NO₂) must first be transformed into NO before it can be measured using the chemiluminescent reaction. NO₂ is converted to NO by a molybdenum NO₂-to-NO converter heated to about 325°C. The ambient air is drawn into the NO₂ analyzer using an external vacuum pump. The sample flows through a particulate filter, a capillary, and then to the mode solenoid valve. The solenoid valve routes the sample either straight to the reaction chamber (NO mode) or through the NO₂-to-NO converter and then to the reaction chamber (NO_x mode). A flow sensor prior to the reaction chamber measures the sample flow.

	Page 4 of 10	SOP Number	WBEA SOP-ANA-003 NO2
		Implementation Date	February 19, 2013
		Last Update Date	February 19, 2013
		Revision	1.00

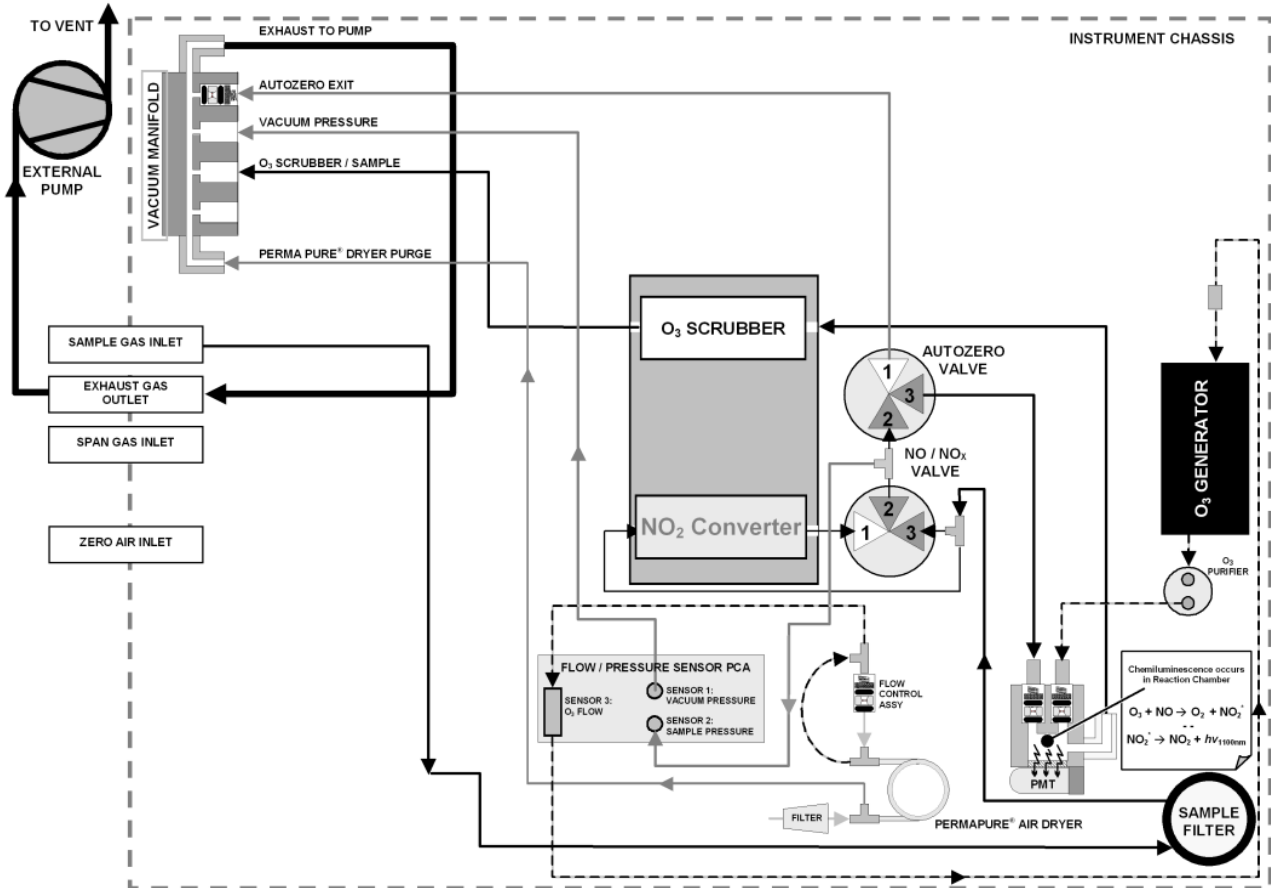

(Figure 2.1 API 200 NO_x analyzer flow path)

Dry air enters the NO₂ analyzer through either a permeable membrane dryer system or a canister of silica gel to remove any moisture. This dry air then flows through a flow sensor, and then through a silent discharge ozonator. The ozonator generates the necessary ozone concentration needed for the chemiluminescent reaction. The ozone reacts with the NO in the ambient air sample to produce electronically excited NO₂ molecules. A photomultiplier tube (PMT) housed in a thermoelectric cooler detects the NO₂ luminescence. The NO and NO_x concentrations calculated in the NO and NO_x modes are stored in memory. The difference between the concentrations is used to calculate the NO₂ concentration. The NO₂ analyzer outputs NO, NO₂, and NO_x concentrations to both the front panel display and the analog outputs.

	Page 5 of 10	SOP Number	WBEA SOP-ANA-003 NO2
		Implementation Date	February 19, 2013
		Last Update Date	February 19, 2013
		Revision	1.00

Measurement Range and Sensitivity

The NO₂ analyzers used in this method are commercially available models. The measurement range is user selectable at ranges between 0 to 1000 parts per billion by volume (ppb). The standard range selection used in the WBEA network is 0 to 1000 ppb.

The detection limit of the analyzer is specified by the manufacturer and specific settings applied to the analyzer when placed in the field. This is also governed by the noise level of the output signal, whether analog or digital. Two times the noise level is generally accepted as the lower detectable limit (LDL); generally it is at the 1.0 ppb level. The health of the analyzer is important as poor health = higher noise = higher LDL.

Equipment and Apparatus

NO₂ analyzers used in the WBEA network include:

- Thermo Environmental Instruments – model 42C, 42i, and related Trace Level analyzers of the same model analyzer
- Teledyne API – model 200A analyzer

NO₂ analyzers in use are all EPA approved and AMD compliant. This does not exclude the use of other equipment that has received the USEPA Reference and Equivalent Method designation.

Interferences

At concentration levels normally encountered in urban ambient air, other Nitrogen based compounds will be converted and subsequently detected in the NO_x mode of the analyzer. These include the following compounds at the listed temperatures:

- PAN (Peroxyacetyl nitrate) - (375°C - 450°C)
- ethyl nitrate; ethyl nitrite; HONO; HNO₃ - (350°C, 375°C, 450°C)
- methyl nitrate, n-propyl nitrate, n-butyl nitrate, nitroresol - (450°C)

As the converter temperature is maintained at 325°C, the influence of these compounds is minimal. For the purposes of this method, NO_x is generally considered to include only NO₂ and NO.

Particulate matter present in the measurement cell can inhibit analyzer response by absorbing NO and NO₂ molecules, thereby not allowing them to luminescence. This problem is normally eliminated by

	Page 6 of 10	SOP Number	WBEA SOP-ANA-003 NO2
		Implementation Date	February 19, 2013
		Last Update Date	February 19, 2013
		Revision	1.00

using a particle filter of 5.0µm pore size made of inert material, such as Teflon, at the sample inlet of the instrument.

Precision and Accuracy

The measurement precision is generally considered to be the “repeatability of the measurement”. Precision of the data output by the analyzer is established by the manufacturer, but confirmed during daily span checks and monthly calibrations

The accuracy of the sensor is generally considered the “deviation from true”. This means how close it is to what it should be. The benchmark of “what it should be” is provided by the Alberta Environment Audit Program staff and the use of high quality standards such as available from the National Institute of Standards and Technology (NIST). As with precision, accuracy is confirmed by the daily span and monthly calibration checks. Refer to the sections identified above for further information on accuracy relating to calibration and audit procedures.

Site Requirements

All NO_x analyzers are housed in a temperature controlled ambient air monitoring shelter in a standard instrument rack. Sample air is brought into the shelter using a glass sample inlet system and made available to the NO_x analyzer. The station is sited according to appendix A-2, Station Site Criteria section of the AMD. Site location for NO_x monitoring should be determined according to the intended application of the monitoring data.

Installation Requirements

All the installation requirements are specified by the manufacturer in the installation procedures of the manual. General requirements listed below must also be followed.

- The ¼ inch outside diameter (inside diameter of 3/16 inch or 1/8 inch) connection tubing from the manifold to the analyzer inlet must be made of Teflon or equivalent material for chemical inertness. The length of tubing must be kept as short as possible and no longer than 10 meters.
- A Teflon particulate filter with a pore size of no larger than 5.0µm must be placed in the sampling line before the air sample enters the detection cells and is recommended to be located as close as possible to the inlet manifold. The holder for such filter must also be made of Teflon, Stainless Steel or Delrin.

	Page 7 of 10	SOP Number	WBEA SOP-ANA-003 NO2
		Implementation Date	February 19, 2013
		Last Update Date	February 19, 2013
		Revision	1.00

- A data acquisition system (DAS) should be connected to the analyzer to record or download the signal output from the analyzer. For connection to record analog voltage signals, the system should be set to match the voltage range of the analyzer output. In the WBEA network the standard is 5V full scale and is scaled to convert the output signal to the concentration range outlined in section 3. For serial or LAN connection there must be a station router in place and configurations made to the analyzer settings, the router, and the data logger. See the DAS operations manual for instructions on configuring these channels.
- The monitoring station temperature should be controlled within the range of 15 to 30°C. It is important to note that the analyzer will operate properly at any temperature within this range; however, the stability of the station temperature is most important.
- Within the vicinity of the station all products containing solvents must be avoided.
- Range Set – the typical range used for monitoring NO₂ is 0 to 1000 ppb. This is done as soon as the analyzer is powered up after installation. Refer to the operations manual for instructions on this procedure.
- The analyzer has the capability to output specific alarms or a general alarm via a contact closure. These outputs are connected to the digital input section of the DAS. See the DAS operations manual for instructions on configuring these channels.

Operating Parameters and Instrument Configuration

The following activities must be performed when operating a continuous automated chemiluminescent NO₂ analyzer in the WBEA network. All operational activities conducted at any ambient monitoring station must be documented in the Doc-It system. This allows other operators to access a history of the station if the regular technician is not available. The following documentation must be available to the operators on site: operational and maintenance manual(s), quality system manual and station site documentation.

Daily Requirements

Zero/Span Check – a zero/span cycle is required every day to verify the analyzer's performance. This involves diverting the sample flow of the analyzer so that the analyzer subsequently samples zero air for the zero cycle and air with a known amount of NO₂ for the span cycle. These two sources are provided by the in-situ calibration system. A zero air point of dilution air only is generated through a saved sequence in the calibrator, and span is generated by a saved calibration point in the calibrator, typically the high point of the routine multipoint calibration sequence. This cycle is controlled by the data system in the station, as it also flags the collected data as calibration and not sample data. During the daily zero/span cycle WBEA runs zero for twenty minutes to ensure stability, followed by a twenty minute span. The remaining twenty minutes of the hour is flagged down to allow the analyzer to return to

	Page 8 of 10	SOP Number	WBEA SOP-ANA-003 NO2
		Implementation Date	February 19, 2013
		Last Update Date	February 19, 2013
		Revision	1.00

ambient air prior to collecting valid data again. Refer to the analyzer manual for more information. When this method is employed a GPT span point is selected in order to convert some of the NO into NO₂ to verify proper operation of the analyzer's molybdenum converter.

Analyzer Test Parameters

The analyzer monitors and displays test functions in order for the operator to monitor the performance of specific systems within the analyzer. These test parameters should be recorded digitally via DAS collection or documented on calibration reports.

Inlet Filter Change

The sample inlet filter is typically replaced when the monthly multipoint calibration is being done. The filter change is completed after the as found points have been completed and before the multipoint calibration is carried out. This is done to establish a reference prior to the removal of the filter.

Analyzer Maintenance

Preventative maintenance tasks should be completed on the analyzer on a periodic basis. These tasks are outlined in the operations manual. A strict regiment of these tasks should be adhered to as they are intended to fix a problem before it happens. Any maintenance must be recorded in the Doc-It system. This is also recorded in the instrument log that accompanies each instrument.

Annual Tasks

The following are preventative maintenance measures intended to keep analyzer operation optimal. For details refer to the operating manual.

- O-ring fittings at the orifices or capillaries must be replaced as ozone will corrode the rubber and increase the probability of leaks.
- Cleaning the reaction chamber to ensure that HNO₂ dust does not build up a residue that can impede the sensitivity of the PMT.
- Rebuild or replace pump to ensure the analyzer is under a consistent vacuum level.

Semi Annual Tasks

- Replace charcoal scrubber upstream of pump; this will prevent the O₃ generated by the NOX analyzer from eating away the seals and depleting the vacuum capacity of the pump. It is ideal to replace this scrubber during pump maintenance (see Annual Tasks).

	Page 9 of 10	SOP Number	WBEA SOP-ANA-003 NO2
		Implementation Date	February 19, 2013
		Last Update Date	February 19, 2013
		Revision	1.00

Multipoint Calibration

Multipoint calibrations are conducted on the NO₂ analyzer to verify precision, accuracy and linearity of the instrument. This procedure must be completed after the analyzer has been installed following at least a 24 hour warm up period, prior to removal, and monthly to comply with Alberta Environment regulations. This procedure is also completed before and after any major maintenance to confirm the precision and accuracy.

Analyzer Audit

NO₂ analyzers operating in Alberta are required to undergo an on-site audit once per year. This audit involves the Alberta Environment Audit Program staff visiting the site with the NIST traceable standards to verify the accuracy and linearity of the instrument.

Calibration Requirement

The calibration procedure for NO₂ analyzers is unique to the calibration of other continuous ambient air analyzers in that it is a two stage calibration. The first stage is the dilution portion and involves generating a known amount of NO which is introduced to the analyzer to verify its performance. A known amount of NO gas will travel through the analyzer in both modes to provide the same signal on both active channels. Three concentrations of NO are generated in order to verify the linearity of the analyzer. Once the dilution portion of the calibration is complete, the Gas Phase Titration (GPT) begins. The GPT involves adding controlled amounts of Ozone to the NO flow generated in the dilution portion of the calibration. This causes the NO to react with the Ozone to form NO₂ which challenges the molybdenum converter to convert the generated NO₂ back to NO to be analyzed. Three levels of Ozone are generated in this phase of the calibration to again verify the linearity of the instrument. There are certain specifics to the NO₂ calibration that are identified in this section. The main calibration procedure can be found in WBEA SOP-OPS-002 Dilution Calibration Procedure.

- Calibration Equipment – NO₂ calibrations can be calibrated using only the dilution method. The calibrator used must also have the capability of generating stable low level concentrations of Ozone for the GPT portion of the calibration.
- Calibration results must be graphed as indicated concentrations (C_i) versus calculated concentrations (C_c) from which the slope of the graph, the intercept and final correction coefficient are calculated.
- The acceptance criteria are slope of 1.0, ±0.05, and intercept of ±3% full scale and a coefficient of correlation (CC) >0.995.

All contents of this website are Copyright © 2013 by the Wood Buffalo Environmental Association and are marked as such. All rights reserved.

	Page 10 of 10	SOP Number	WBEA SOP-ANA-003 NO2
		Implementation Date	February 19, 2013
		Last Update Date	February 19, 2013
		Revision	1.00

- A zero/span check cycle is run through the DAS following the calibration to verify the span values and to pick up and zero offset.
- A recorded trace of the instrument, response over time is required to demonstrate stability and accuracy.
- NO/NO_x/NO₂ calibrations must have points above and below the one hour regulatory average of 170 ppb.
- Two points of NO must bookend the GPT (beginning and end); while these points do not need to indicate 20 minutes of stability, 10 minutes is desirable.
- During the GPT the NO and NO₂ points should be equal to the NO_x channel to demonstrate converter efficiency.

Data Collection and Management

The analog output of the NO/NO₂/NO_x analyzers is typically wired to the analog input channels of the station Campbell's Scientific CR3000 Micrologger. This data recorded at 5 minute intervals and is then polled remotely via cellular modem. Alternatively the data can be polled digitally via the serial or Ethernet port, and can be accompanied by the diagnostic or meta-data information.

Reference Documents

- *THERMO ENVIRONMENTAL INSTRUMENTS (TEI) MODELS 42, 42C & 42I NO₂ ANALYZER OPERATING MANUAL* THERMO ENVIRONMENTAL INSTRUMENTS INC. Franklin MA, 2000, 5-1 – 7-9.
- State of California Air Resources Board (CARB) Method Volume II Standard Operating Procedures for Air Quality Monitoring Appendix W dated April 1996
- Alberta Monitoring Directive (1989) and Amendments (2006)